

Custom Pig Tray

16" & Above (406.5mm & Up)

Apache's Custom Pig Trays are not only for displaying our industry leading cleaning tools, the pig tray provides assistance with transportation, storage and during maintenance operations in the field when launching and receiving your cleaning tool through the pipeline.

Featuring an all-aluminum frame, the construction of each tray is based on customer specifications and optimized by Apache's in house Engineering department. Apache's custom pig trays are available with a plethora of options and customizable details!

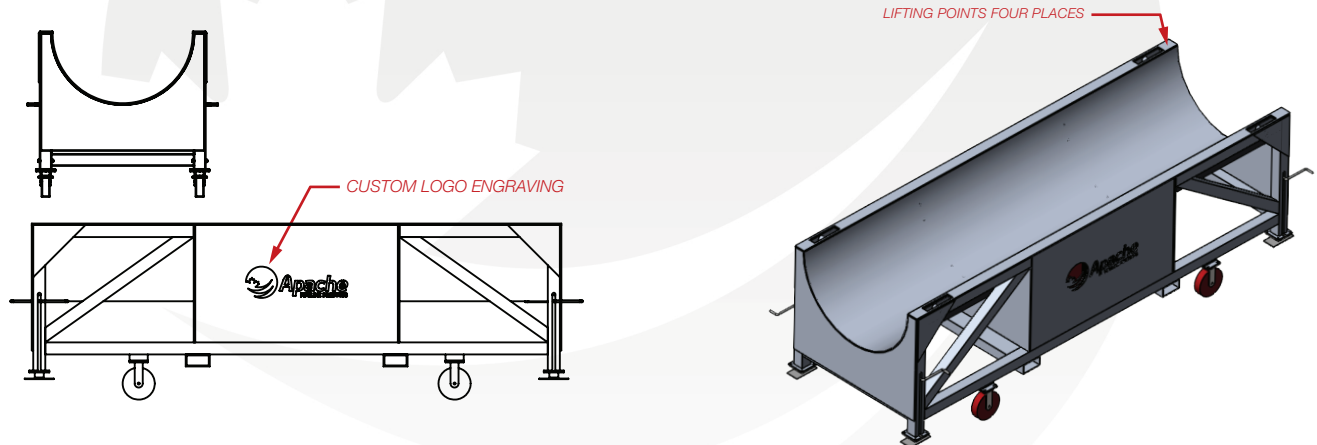

Features & Benefits:

- Equipped with completely adjustable steel legs to suit your maintenance operation's &/or storage's location.
- Custom length's based on dimensions of cleaning &/or inspection tool(s).
- Certified for lifting as per **ASME B30.20**.
- All aluminum frame is lightweight and non-sparking.

Options Available:

- Forklift sleeves (aluminum).
- Company Name &/or Logo engraved onto front of tray.
- All Steel Frame
- Hydraulic Cylinder: Heavy Duty Industrial grade, provides thrust to push pig from tray into pig launcher, or to pull pig from receiver.
- Industrial Hydraulic Power Unit
- Trolley car for push/pull, maintains alignment of hydraulic cylinder, 12 casters to resist any misalignment.
- Hogging pole parts, custom made for hydraulic power pig tray, all Aluminum (except hook which is plastic coated steel).
- Rack for hogging poles and toolbox fixed in place for loose components.
- Drip tray for collection of pipeline fluid. Extends beyond end of pig tray, slides back to store and lock in place under pig tray unit. Includes drainage slots to allow fluid coming from the pig to be collected in drip tray.