

ALL URETHANE

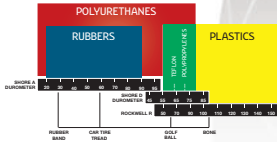

Durometer Chart

Pg. 4-2

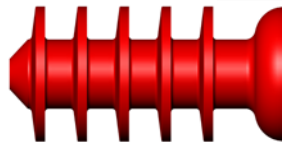

Purger I

2 - 36"

Pg. 4-3

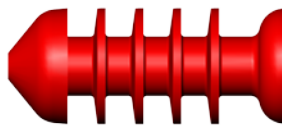

Purger II

2 - 24"

Pg. 4-4

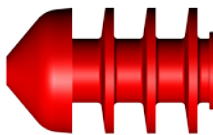

Purger VP

2 - 12"

Pg. 4-5

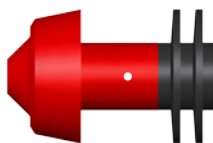

Hurricane FP

3 - 12"

Pg. 4-6



Hurricane LP

3 - 12"

Pg. 4-7

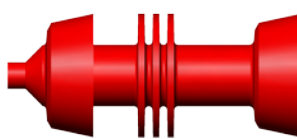

Hurricane I

3 - 12"

Pg. 4-8



Hurricane II

3 - 12"

Pg. 4-9

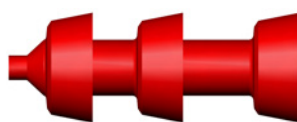

Hurricane III

3 - 12"

Pg. 4-10

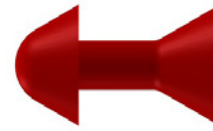

Tornado I

2 - 4"

Pg. 4-11

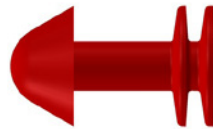

Tornado II

2 - 4"

Pg. 4-12



Tornado III

2 - 4"

Pg. 4-13

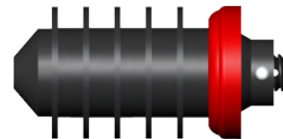

Versi I

6 - 20"

Pg. 4-14

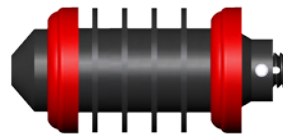

Versi II

6 - 20"

Pg. 4-15



Versi III

6 - 20"

Pg. 4-16

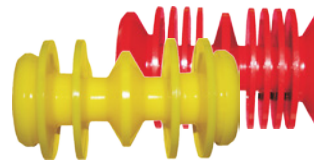

VIPRS® & SUD®

2 - 10"

Pg. 4-17

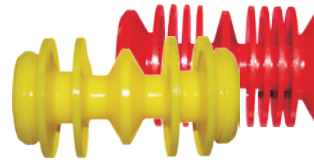

VIPRS® & SUD®

2 - 10"

Pg. 4-18

60-63 DUROMETER

Very soft and pliable

70-75 DUROMETER

Somewhat firm, but quite flexible

80-85 DUROMETER

Firm with fair flexibility
Most common for solid-cast pigs

ALL URETHANE

DUROMETER

What does “durometer” mean and why is it important? Pipeline pigs play many roles. From cleaning and removing debris to separating and batching dissimilar fluids, they’re essential tools of the trade, especially for maintaining pipelines. And because no two tasks – or pipeline - are exactly alike, the characteristics of the best pig for the job will vary.

For example, a long section of pipeline choked with debris will require much more aggressive cleaning and scraping by a rugged, hardwearing pig that can withstand the rigors of the process, as opposed to a shorter line in need of light cleaning.

A key characteristic of a pig lies in the type of material from which it is made. This is where “durometer” comes in. Durometer is the term used for one of several measures of the hardness of a material. We define hardness as a material’s resistance to permanent indentation. To illustrate, in the world of polyurethane pipeline pigs, the hardness scale used is called the “Shore A”. Our polyurethanes typically range from 60 to 90 on the Shore A Scale. That said, we can easily expand that range for special applications should a customer require it.

Compared with rubber, polyurethane is a harder, stronger product, giving it the ability to handle harsher conditions, higher load and greater impact. The chart illustrates the unique properties of polyurethanes.

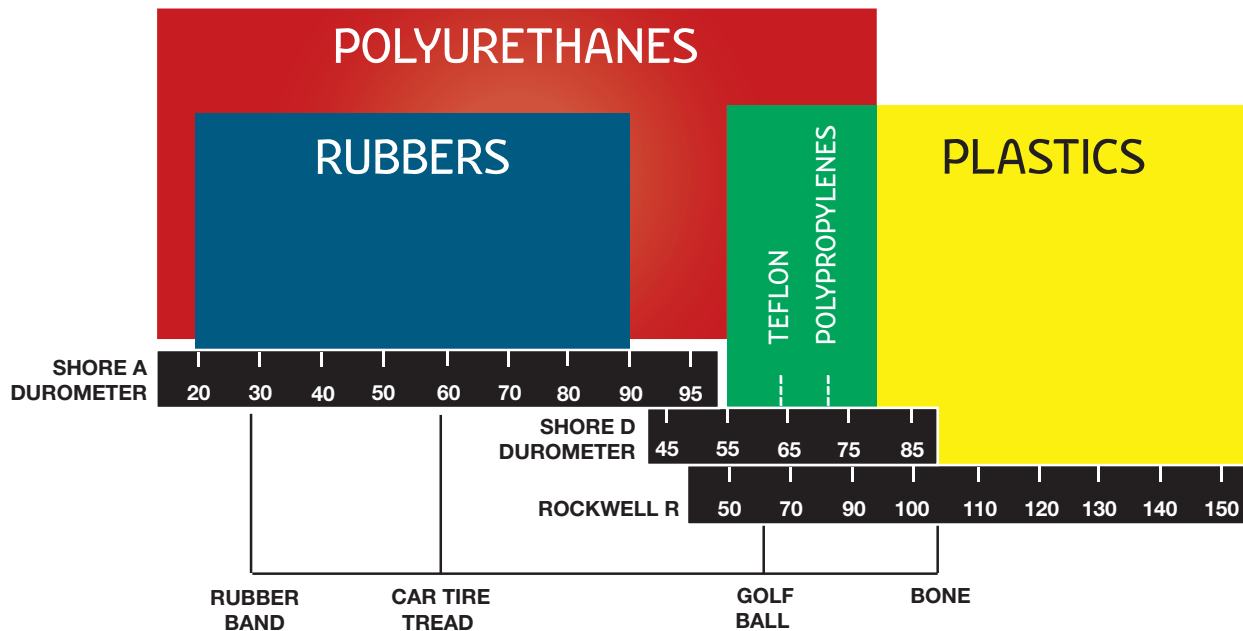

With regard to pipeline pigs, each durometer has advantages and disadvantages. Each of the descriptive headings below also indicates Apache’s standard color for each durometer.

- **60-63 Durometer:** Very soft and pliable; good for passing through restrictions and turning tight radius bends; can be used in non-steel pipelines (fiberglass, HDPE or lined pipe); less effective for cleaning and scraping due to its softness; a shorter pig lifespan due to wear and tear; lower resistance to extreme conditions, such as high hydrogen sulfide gas or chemicals. Pigs in this durometer are great for low pressure applications.
- **70-75 Durometer:** Somewhat firm, but quite flexible; moderate cleaning and scraping effectiveness; medium-wear resistance.
- **80-85 Durometer:** The most common durometer used for solid-cast pigs; firm with fair flexibility; very effective for cleaning and scraping; high level of wear resistance; moderate resistance to hydrogen sulfide gas or chemicals.
- **90-95 Durometer:** Very hard with little to no flexibility; rarely used for solid cast pigs; primarily used for custom urethane applications (i.e. rollers, bumpers and spacers).

Options Available:

- Food grade.
- High temperature material.

1575 - 90 Ave Edmonton, AB Canada T6P 0E2

4-2 Ph: 780.416.4850 | Fax: 780.416.4829 | apachepipe.com | Email: sales@apachepipe.com

world class world wide

ALL URETHANE

PURGER I™ - solid cast

2-36" (51-914mm)

The Purger™ Series pig is an incredibly tough, all-urethane pipeline pig that requires absolutely no maintenance and is an excellent pig for product evacuation. The Purger I™ is an extremely efficient batching, cleaning and displacement pig. Its multi-disc design ensures that sealing elements are always centered in the pipeline, resulting in consistent wear over time.

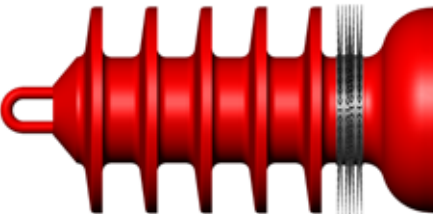
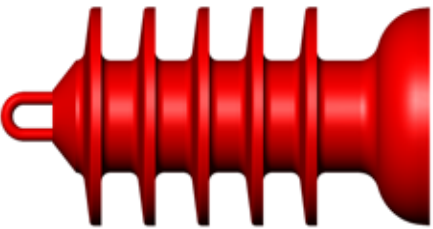
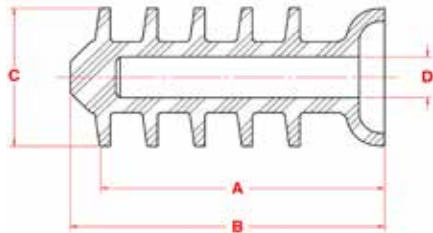

Size	A	B	C	D	Weight	Part #
2"	4.500	5.000	2.250	0.500	0.5	71-0185-02
3"	6.750	7.500	3.375	1.000	1.0	71-0185-03
4"	7.500	8.500	4.375	1.250	2.0	71-0185-04
6"	11.500	13.250	6.375	1.500	7.0	71-0185-06
8"	15.250	17.000	8.625	3.000	15	71-0185-08
10"	17.500	19.750	10.625	3.875	26	71-0185-10
12"	20.500	23.000	12.500	4.750	44	71-0185-12
14"	23.500	26.000	14.250	5.750	56	71-0185-14
16"	25.750	28.500	16.375	6.750	84	71-0185-16
18"	29.000	35.000	18.000	7.750	92	71-0185-18
20"	29.500	33.750	20.000	7.875	118	71-0185-20
22"	32.750	37.250	22.000	9.000	183	71-0185-22
24"	35.750	39.750	24.000	9.875	208	71-0185-24
30"	44.000	52.000	30.000	12.875	337	71-0185-30
36"	48.500	61.000	36.000	18.625	505	71-0185-36

*Part numbers shown are for 85 Durometer (62 and 72 also available)

Features & Benefits:

- Lightweight – no metal components.
- Improved sealing as hollow core allows pressure to expand the pig body.
- Multiple seals provide excellent product interface.
- Standard hollow core to accommodate an electronic transmitter.

Options Available:

- Solid core.
- Variety of durometers.
- Wrap brushes in the following types and trim materials:
 1. Trim types – flat wire.
 2. Trim material – carbon steel, stainless steel or plastic.
- Magnets can be used to provide a change in magnetic field required by non-intrusive pig signaler detection devices. Trip magnets are available for 4" - 36".
- Rattler 16" – 36" sizes only.
- Custom lengths available on request.

Designed to negotiate 1.5D bends, the Purger I moves reliably through complex lines.

60-63 DUROMETER
Very soft and pliable

70-75 DUROMETER
Somewhat firm, but quite flexible

80-85 DUROMETER
Firm with fair flexibility
Most common for solid-cast pigs

ALL URETHANE

PURGER II™ - solid cast

2-24" (51-610mm)

The Apache Purger II™ is very lightweight and easy to launch. Designed standard with four sealer discs and two cups, back and front, it is very effective and versatile for both cleaning and batching.

Its one-piece molded design features multiple seals, making it an extremely efficient batching, cleaning and displacement pig. Unlike metal pigs, the solid urethane construction means that parts are never lost. Also, the sealing elements are always centered in the pipeline, resulting in consistent wear over time.

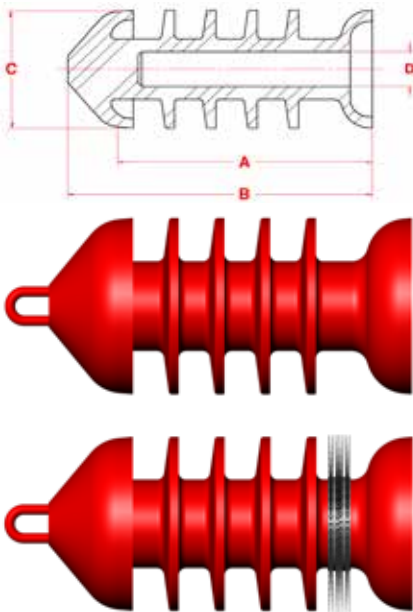

Size	A	B	C	D	Weight	Part #
2"	4.250	5.375	2.250	0.500	0.5	71-0285-02
3"	6.750	8.375	3.375	1.000	1.3	71-0285-03
4"	7.500	9.500	4.375	1.250	3.0	71-0285-04
6"	11.500	15.000	6.375	1.500	7.8	71-0285-06
8"	15.500	19.250	8.625	3.000	18	71-0285-08
10"	18.250	22.000	10.625	3.875	28	71-0285-10
12"	22.000	26.500	12.500	4.750	50	71-0285-12
14"	24.000	31.000	14.250	5.750	58	71-0285-14
16"	24.500	33.000	16.375	6.750	75	71-0285-16
18"	27.000	36.000	18.000	8.750	109	71-0285-18
20"	30.375	39.000	20.000	7.875	126	71-0285-20
22"	33.625	43.000	22.000	9.000	223	71-0285-22
24"	36.750	46.000	24.000	9.875	247	71-0285-24

*Part numbers shown are for 85 Durometer (62 and 72 also available)

Features & Benefits:

- Lightweight – no metal components.
- Improved sealing as hollow core allows pressure to expand the pig body.
- Excellent for nitrogen purging applications.
- Standard hollow core to accommodate an electronic transmitter.

Designed to negotiate 1.5D bends, the Purger II moves reliably through piping systems.

Options Available:

- Solid core.
- Variety of durometers.
- Circular flange brushes or block brushes in the following types and trim materials:
 1. Trim types – flat wire.
 2. Trim material – carbon steel, stainless steel or plastic.
- Magnets can be used to provide a change in magnetic field required by non-intrusive pig signaler detection devices. Trip magnets are available for 4" - 24".
- Rattler 16" – 24" sizes only.
- Custom lengths available on request.

60-63 DUROMETER
Very soft and pliable

70-75 DUROMETER
Somewhat firm, but quite flexible

80-85 DUROMETER
Firm with fair flexibility
Most common for solid-cast pigs

ALL URETHANE

PURGER VP™ - valve pig

2-12" (51-305mm)

Looking for a way to optimize your pipeline maintenance program? Apache has the answer. It's called the Purger VP™, and it's the latest addition to the Purger™ Series of solid-cast urethane pigs. The "VP" stands for "valve pig." This means that it is specially designed so that it can be launched and received by nearly any pigging valve on the market today. As it moves steadily through the line, clearing away troublesome debris and residue, rest assured that the line is being thoroughly cleaned, and the Purger VP will arrive in the receiver on schedule.

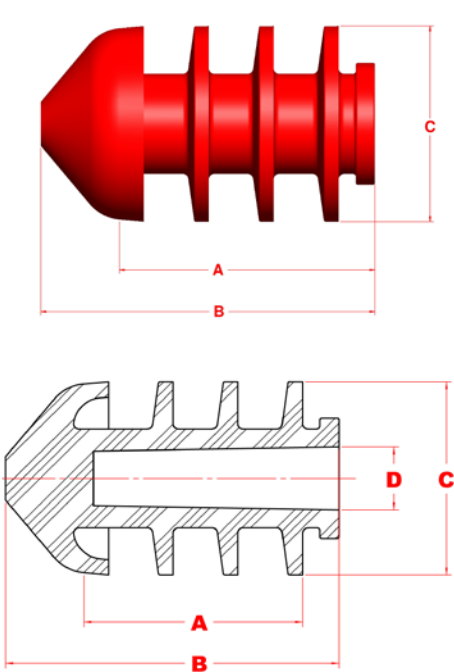

Size	A	B	C	D	Weight	Part #
2"	2.375	4.000	2.250	-	0.5	71-0985-02S
3"	3.750	5.750	3.375	-	1.1	71-0985-03S
4"	3.875	7.375	4.375	-	2.4	71-0985-04S
6"	5.750	10.250	6.375	-	6.0	71-0985-06S
8"	8.375	14.750	8.500	2.875	12	71-0985-08
10"	9.250	15.250	10.500	3.875	19	71-0985-10
12"	11.250	18.500	12.500	4.500	33	71-0985-12

*Part numbers shown are for 85 Durometer (62 and 72 also available)

Note: sizes 2"- 6" come standard as solid core, but are available in hollow core as well.

Features & Benefits:

- Lightweight – no metal components.
- Multiple seals provide excellent product interface.
- Can be utilized in Argus™, Masterflo™ and Meridian™ valves.

Designed to negotiate 1.5D bends, the Series Purger VP moves reliably through piping systems.

Options Available:

- Solid core. (Note: sizes 8"- 12" come standard as hollow core, but are available in solid core.)
- Variety of durometers.
- Circular wrap brushes in the following types and trim materials:
 1. Trim types – flat wire.
 2. Trim material – carbon steel, stainless steel or plastic.
- Custom lengths available on request.

60-63 DUROMETER

Very soft and pliable

70-75 DUROMETER

Somewhat firm, but quite flexible

80-85 DUROMETER

Firm with fair flexibility
Most common for solid-cast pigs

* Trademark names

1575 - 90 Ave Edmonton, AB Canada T6P 0E2

Ph: 780.416.4850 | Fax: 780.416.4829 | apachepipe.com | Email: sales@apachepipe.com

4-5

world class world wide

ALLURETHANE

HURRICANE FILMING PIGS - solid cast

3-12" (76-305mm)

Stop corrosion in its tracks. That's what we set out to do when we developed the Hurricane LP-FP double-pig train method. As every pipeline engineer knows, coating the interior of the line with a quality corrosion inhibitor is one of the best ways to keep it from corroding. The challenge? How to apply inhibitor in a controlled manner.

THE LP ROLE

The Hurricane Lead Pig (LP) acts as the lead pig of a double-pig train. It carries inhibitor or biocide treatment, allowing minimal by-pass. The inhibitor is contained between the LP and the Hurricane Filming Pig (FP) pig. As the train moves through the line, the FP leaves a film of inhibitor on the pipe wall.

THE FP ROLE

The design of the dual-durometer Hurricane FP is truly unique. It features a hollow front mandrel with two port holes in the center of the mandrel. This allows the inhibitor to travel to the front hollow mandrel and through the two port holes on either side of the mandrel. The inhibitor is then trapped between the front conical cup, and back two soft discs to leave a film of inhibitor on the pipe wall.

The Hurricane LP-FP method: the ideal solution for controlled, efficient pipe wall filming.

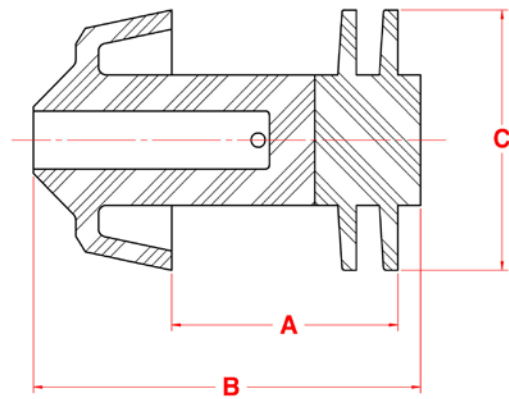
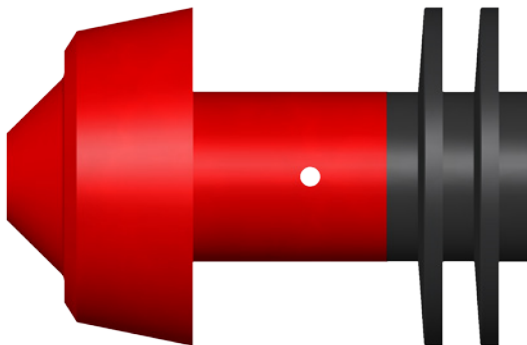

Size	A	B	C	Weight	Part #
3"	2.500	4.875	3.375	1.0	74-0462-03
4"	3.625	6.250	4.375	2.0	74-0462-04
6"	5.375	8.750	6.500	4.0	74-0462-06
8"	7.625	11.750	8.500	10	74-0462-08
10"	9.625	14.125	10.625	20	74-0462-10
12"	10.125	15.375	12.500	32	74-0462-12

Features & Benefits:

- Lightweight – no metal components.
- Can be launched in most common pigging valves.

Designed to negotiate 1.5D bends, the Filming Pig moves reliably through piping systems.



Check out apachepipe.com/animations.html for videos on filming pigs.

ALL URETHANE

HURRICANE LEAD PIGS - solid cast

3-12" (76-305mm)

Stop corrosion in its tracks. That's what we set out to do when we developed the Hurricane LP-FP double-pig train method. As every pipeline engineer knows, coating the interior of the line with a quality corrosion inhibitor is one of the best ways to keep it from corroding. The challenge? How to apply inhibitor in a controlled manner.

THE LP ROLE

The Hurricane Lead Pig (LP) acts as the lead pig of a double-pig train. It carries inhibitor or biocide treatment, allowing minimal by-pass. The inhibitor is contained between the LP and the Hurricane Filming Pig (FP) pig. As the train moves through the line, the FP leaves a film of inhibitor on the pipe wall.

THE FP ROLE

The design of the dual-durometer Hurricane FP is truly unique. It features a hollow front mandrel with two port holes in the center of the mandrel. This allows the inhibitor to travel to the front hollow mandrel and through the two port holes on either side of the mandrel. The inhibitor is then trapped between the front conical cup, and back two soft discs to leave a film of inhibitor on the pipe wall.

Similar in appearance to the Hurricane Filming Pig, the Hurricane LP is manufactured with 72 durometer urethane and has a rear hollow cavity.

The Hurricane LP-FP method: the ideal solution for controlled, efficient pipe wall filming.

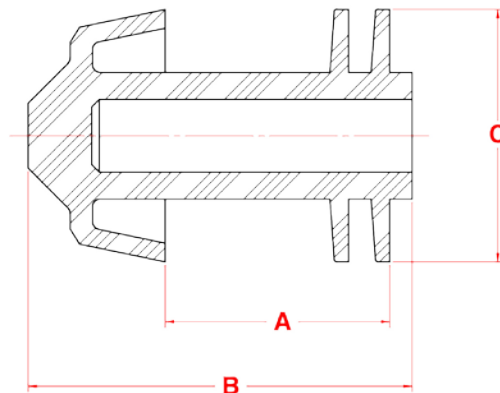
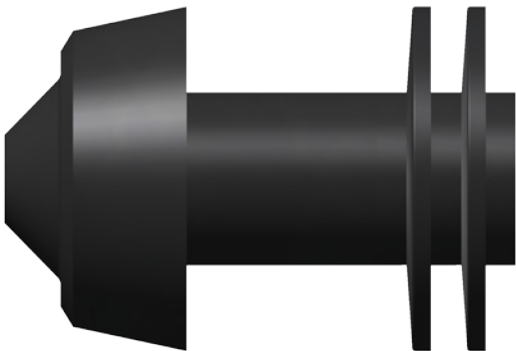

Size	A	B	C	Weight	Part #
3"	2.500	4.875	3.375	0.7	74-0572-03S
4"	3.625	6.250	4.375	1.2	74-0572-04S
6"	5.375	8.750	6.500	3.4	74-0572-06S
8"	7.625	11.750	8.500	9.3	74-0572-08S
10"	9.625	14.125	10.625	15	74-0572-10S
12"	10.125	15.375	12.500	25	74-0572-12S

Features & Benefits:

- Lightweight – no metal components.
- Can be launched in most common pigging valves.
- Standard hollow core to house an electronic transmitter.

Designed to negotiate 1.5D bends, the Lead Pig moves reliably through piping systems.



Check out apachepipe.com/animations.html for videos on lead pigs.

ALL URETHANE

HURRICANE I - solid cast

3-12" (76-305mm)

The Hurricane I is a single-mold urethane cup-disc pig. It is very lightweight, making it easy for maximum cleaning. Strategically placed cups and discs make it possible for the Hurricane to navigate through restrictions in valves and pass through tees.

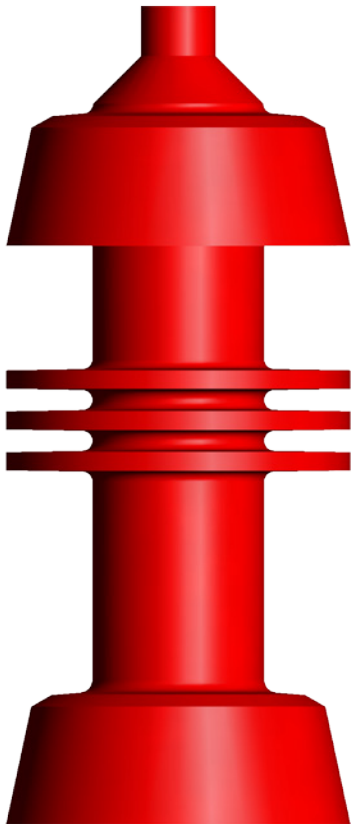

Size	A	B	C	D	Weight	Part #
3"	5.750	7.750	3.375	1.000	1.0	74-0185-03
4"	7.375	9.625	4.500	1.500	1.7	74-0185-04
6"	10.125	13.125	6.500	2.000	5.2	74-0185-06
8"	13.125	17.500	8.625	2.875	13	74-0185-08
10"	16.000	20.500	10.750	3.750	21	74-0185-10
12"	20.500	23.000	12.625	4.625	48	74-0185-12

**Part numbers shown are for 85 Durometer (62 and 72 also available)*

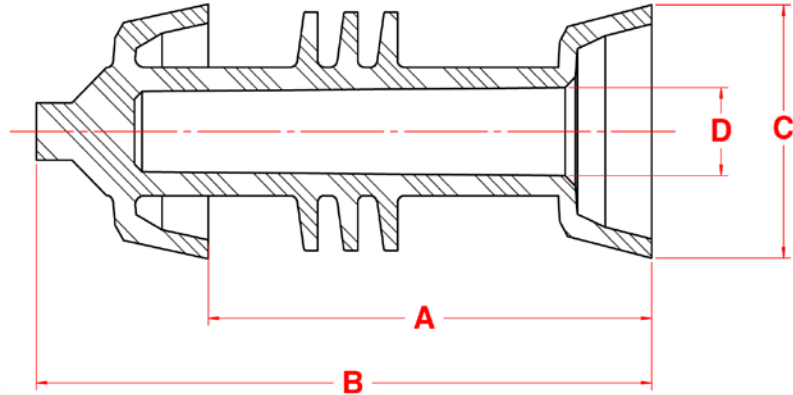

Features & Benefits:

- Solid-cast urethane.
- Lightweight.
- Reusable.
- Standard hollow cavity to house a transmitter.

Designed to negotiate 1.5D bends, the Hurricane I moves reliably through piping systems.

Options Available:

- Solid core.
- Variety of sizes durometers.
- Wrap brushes in the following types and trim materials:
 1. Trim types – flat wire.
 2. Trim material – carbon steel, stainless steel or plastic.
- Magnets can be used to provide a change in magnetic field required by non-intrusive pig signaler detection devices.

60-63 DUROMETER

Very soft and pliable

70-75 DUROMETER

Somewhat firm, but quite flexible

80-85 DUROMETER

Firm with fair flexibility
Most common for solid-cast pigs

ALL URETHANE

HURRICANE II - solid cast

3-12" (76-305mm)

The solid-cast Hurricane II is a single-mold urethane cup pig. It is very lightweight, making it easy for maximum cleaning. The strategically placed cups makes it possible for the Hurricane II to navigate through restrictions in valves and pass through tees.

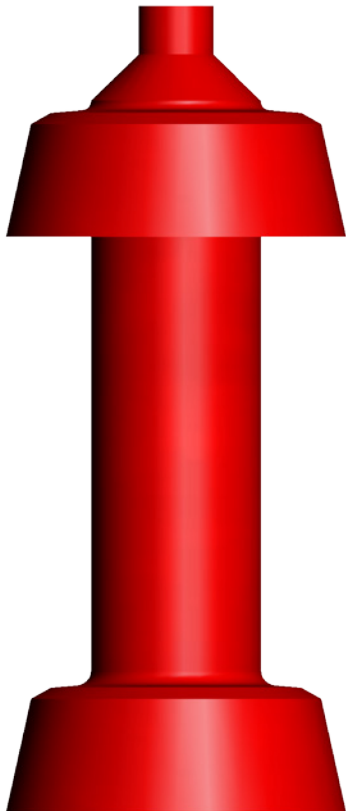

Size	A	B	C	D	Weight	Part #
3"	6.250	7.875	3.375	1.000	0.8	74-0285-03
4"	8.000	9.750	4.500	1.500	1.4	74-0285-04
6"	10.750	13.000	6.500	2.000	3.7	74-0285-06
8"	14.000	16.750	8.625	2.875	9.7	74-0285-08
10"	16.000	20.500	10.750	3.750	21	74-0285-10
12"	20.500	23.000	12.625	4.625	48	74-0285-12

*Part numbers shown are for 85 Durometer (62 and 72 also available)

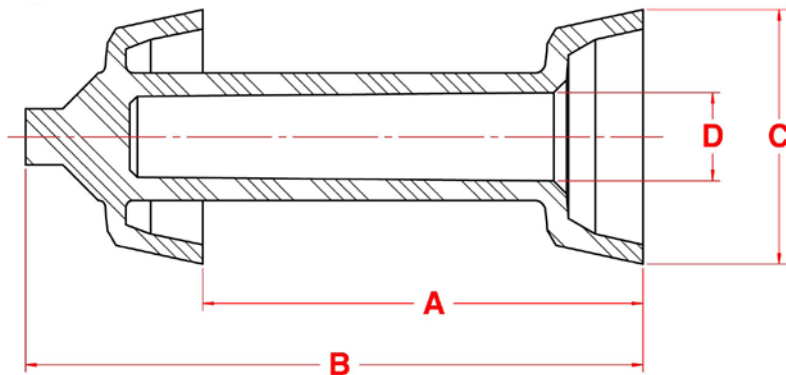

Features & Benefits:

- Solid-cast urethane.
- Lightweight.
- Standard hollow cavity to house a transmitter.

Designed to negotiate 1.5D bends, the Hurricane II moves reliably through piping systems.

Options Available:

- Solid core.
- Variety of durometers.
- Wrap brushes in the following types and trim materials:
 1. Trim types – flat wire.
 2. Trim material – carbon steel, stainless steel or plastic.
- Magnets can be used to provide a change in magnetic field required by non-intrusive pig signaler detection devices.

60-63 DUROMETER

Very soft and pliable

70-75 DUROMETER

Somewhat firm, but quite flexible

80-85 DUROMETER

Firm with fair flexibility
Most common for solid-cast pigs

ALL URETHANE

HURRICANE III - solid cast

3-12" (76-305mm)

The solid-cast Hurricane III is a single-mold urethane cup pig. It is very lightweight, making it easy for maximum cleaning. The strategically placed cups make it possible for the Hurricane III to navigate through restrictions in valves and pass through tees.

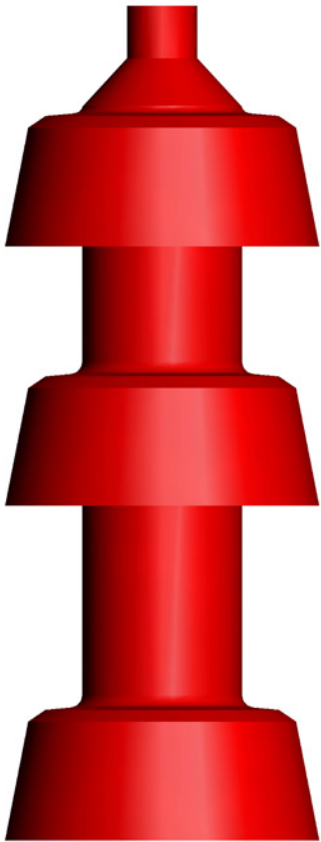

Size	A	B	C	D	Weight	Part #
3"	5.750	7.750	3.750	1.000	1.0	74-0385-03
4"	7.125	9.625	4.500	1.500	1.8	74-0385-04
6"	9.875	12.500	6.500	2.000	4.6	74-0385-06
8"	12.375	16.250	8.625	2.875	12	74-0385-08
10"	15.750	20.750	10.750	3.750	19	74-0385-10
12"	20.500	23.000	12.625	4.625	48	74-0385-12

**Part numbers shown are for 85 Durometer (62 and 72 also available)*

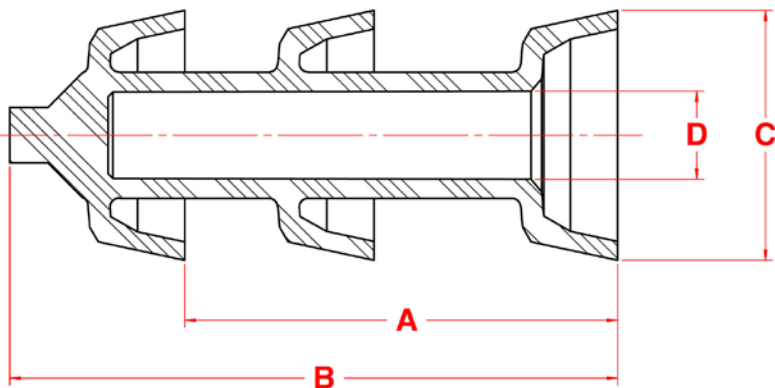

Features & Benefits:

- Solid-cast urethane.
- Lightweight.
- Standard hollow cavity to house a transmitter.

Designed to negotiate 1.5D bends, the Hurricane III moves reliably through piping systems.

Options Available:

- Solid core.
- Variety of durometers.
- Wrap brushes in the following types and trim materials:
 1. Trim types – flat wire.
 2. Trim material – carbon steel, stainless steel or plastic.
- Magnets can be used to provide a change in magnetic field required by non-intrusive pig signaler detection devices.

60-63 DUROMETER
Very soft and pliable

70-75 DUROMETER
Somewhat firm, but quite flexible

80-85 DUROMETER
Firm with fair flexibility
Most common for solid-cast pigs

ALL URETHANE

TORNADO I

2-4" (51-102mm)

Never underestimate the tiny Tornado I. Its compact size is a must for cleaning small diameter pipelines. The field-proven Tornado I effectively cleans small diameter lines, such as those found in crude oil gathering systems.

Time and time again, flow rates rise after being cleaned with a Tornado I.

How is this possible? The unique cup design permits this pig to travel through short radius bends. The Tornado I is designed for use in both non-metallic pipe and steel lines. Its strength lies in proving a line in a pipe network prior to operational pigging, as opposed to clearing solids or aggressive cleaning.

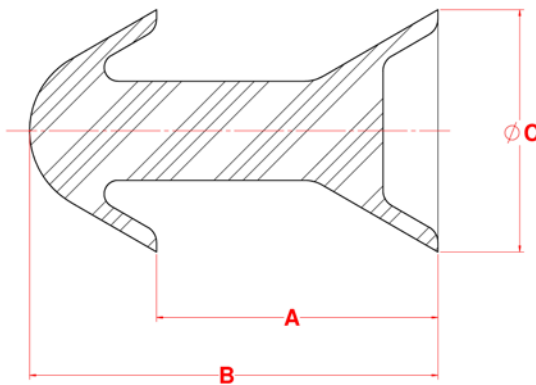

Size	A	B	C
2"	3.000	4.500	2.125
3"	4.125	5.875	3.250
4"	4.875	7.250	4.375



Size	62 Durometer	72 Durometer	85 Durometer
2"	72-0162-02S	72-0172-02S	72-0185-02S
3"	72-0162-03S	72-0172-03S	72-0185-03S
4"	72-0162-04S	72-0172-04S	72-0185-04S

Features & Benefits:

- Solid cast urethane.
- Lightweight.

Designed to negotiate 1.5D bends, the Tornado I moves reliably through piping systems.

Options Available:

- Available in different durometers.

60-63 DUROMETER

Very soft and pliable

70-75 DUROMETER

Somewhat firm, but quite flexible

80-85 DUROMETER

Firm with fair flexibility
Most common for solid-cast pigs

ALL URETHANE

TORNADO II

2-4" (51-102mm)

Never underestimate the tiny Tornado II. Its compact size is a must for cleaning small diameter pipelines.

Time and time again, flow rates rise after being cleaned with the Tornado II.

How is this possible? The discs featured on the Tornado II make it easy for it to traverse through any line with maximum efficiency. Designed for use in non-metallic pipe and steel lines, its strength lies in proving a line in a pipe network prior to operational pigging, as opposed to clearing solids or aggressive cleaning.

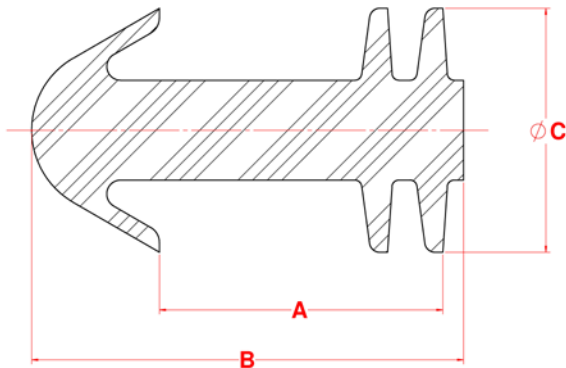

Size	A	B	C
2"	3.000	4.500	2.125
3"	4.125	5.875	3.250
4"	4.875	7.250	4.375



Size	62 Durometer	72 Durometer	85 Durometer
2"	72-0262-02S	72-0272-02S	72-0285-02S
3"	72-0262-03S	72-0272-03S	72-0285-03S
4"	72-0262-04S	72-0272-04S	72-0285-04S

Features & Benefits:

- Solid-cast urethane.
- Lightweight.

Designed to negotiate 1.5D bends, the Tornado II moves reliably through piping systems.

Options Available:

- Available in different durometers.

60-63 DUROMETER

Very soft and pliable

70-75 DUROMETER

Somewhat firm, but quite flexible

80-85 DUROMETER

Firm with fair flexibility
Most common for solid-cast pigs

1575 - 90 Ave Edmonton, AB Canada T6P 0E2

4-12 Ph: 780.416.4850 | Fax: 780.416.4829 | apachepipe.com | Email: sales@apachepipe.com

world class world wide

ALL URETHANE

TORNADO III

2-4" (51-102mm)

Never underestimate the tiny Tornado III. Its compact size is a must for cleaning small diameter pipelines.

Time and time again, flow rates rise after being cleaned with the Tornado III.

How is this possible? The discs and cups featured on the Tornado III make it easy for it to traverse through any line with maximum efficiency. Designed for use in non-metallic pipe and steel lines, its strength lies in proving a line in a pipe network prior to operational pigging, as opposed to clearing solids or aggressive cleaning.

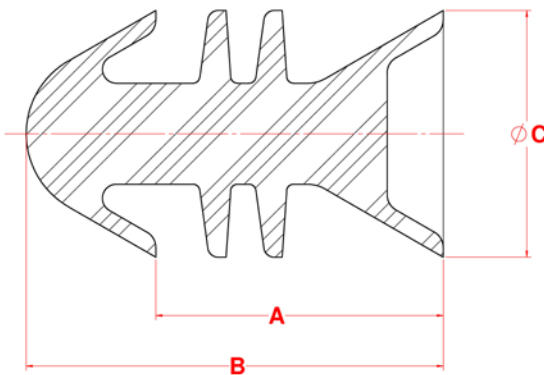

Size	A	B	C
2"	3.000	4.500	2.125
3"	4.125	5.875	3.250
4"	4.875	7.250	4.375

Size	62 Durometer	72 Durometer	85 Durometer
2"	72-0362-02S	72-0372-02S	72-0385-02S
3"	72-0362-03S	72-0372-03S	72-0385-03S
4"	72-0362-04S	72-0372-04S	72-0385-04S



Features & Benefits:

- Solid-cast urethane.
- Lightweight.

Designed to negotiate 1.5D bends, the Tornado III moves reliably through piping systems.

Options Available:

- Available in different durometers.

60-63 DUROMETER

Very soft and pliable

70-75 DUROMETER

Somewhat firm, but quite flexible

80-85 DUROMETER

Firm with fair flexibility
Most common for solid-cast pigs

ALL URETHANE

VERSI I - modular cast

6-20" (152-508mm)

Versatility is the name of the game for the durable, lightweight Series Versi I. Because it can do so many jobs, this all-urethane pipeline pig is extremely economical. By fitting it with a combination of a sealer and cup, it is very effective and versatile for cleaning, batching, and displacement operations.

The solid urethane shaft of the Versi I is very flexible. This means that over time, sealing elements wear evenly, addressing an inherent problem with heavy steel mandrel shafts.

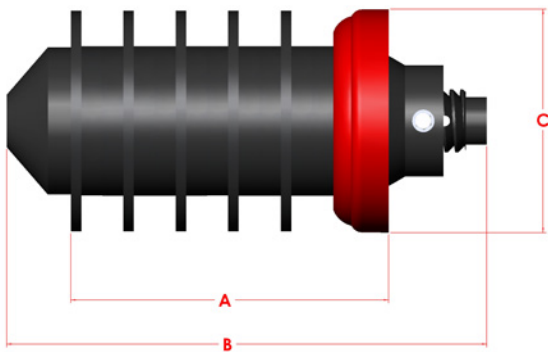

Size	A	B	C	Part #
6"	9.125	14.000	6.375	73-0551-06
8"	12.250	18.625	8.500	73-0551-08
10"	15.125	22.875	10.625	73-0551-10
12"	18.875	26.375	12.500	73-0551-12
14"	20.675	27.625	13.875	73-0551-14
16"	24.500	33.875	16.000	73-0551-16
20"	29.000	38.375	19.875	73-0551-20

Features & Benefits:

- There are no metal parts to bend, corrode or damage pipe lining.
- Rather than replacing the entire assembly when individual parts become worn, they are easily removed and replaced, saving time and money.
- Every Series Versi I pig is equipped with Apache cups and discs. As with all of Apache products, they were specifically developed to perform, efficiently and reliably. To maximize durability, they're made from Reliathane, Apache's special blend of wear-resistant polyurethane.
- To use a Series Versi I pig for different applications, cups can simply be added or reconfigured.

Designed to negotiate 1.5D bends, the Versi I pig moves reliably through piping systems.

Options Available:

- Variety of configurations and durometers.
- Circular flange brushes in the following types and trim materials:
 1. Trim types – flat wire or pencil.
 2. Trim material – carbon steel, stainless steel or plastic.

ALL URETHANE

VERSI II - modular cast

6-20" (152-508mm)

Versatility is the name of the game for the durable, lightweight Series Versi II. Because it can do so many jobs, this all-urethane pipeline pig is extremely economical. By fitting it with a combination of a sealer and cup, it is very effective and versatile for cleaning, batching, and displacement operations.

The solid urethane shaft of the Versi II is very flexible. This means that over time, sealing elements wear evenly, addressing an inherent problem with heavy steel mandrel shafts.

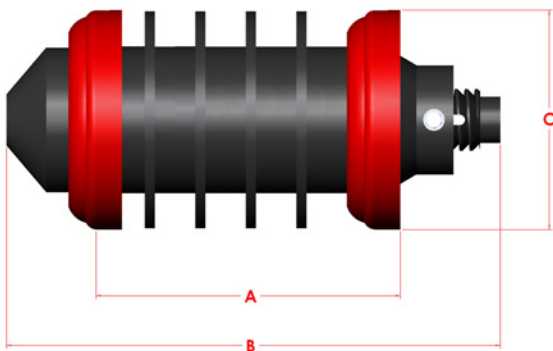

Size	A	B	C	Part #
6"	9.250	15.375	6.375	73-0552-06
8"	12.625	19.875	8.500	73-0552-08
10"	15.000	24.375	10.625	73-0552-10
12"	18.625	27.625	12.500	73-0552-12
14"	21.500	30.750	13.875	73-0552-14
16"	24.000	33.875	16.000	73-0552-16
20"	30.125	43.125	19.875	73-0552-20

Features & Benefits:

- There are no metal parts to bend, corrode or damage pipe lining.
- Rather than replacing the entire assembly when individual parts become worn, they are easily removed and replaced, saving time and money.
- Every Series Versi II pig is equipped with Apache cups and discs. As with all of Apache products, they were specifically developed to perform, efficiently and reliably. To maximize durability, they're made from Reliathane, Apache's special blend of wear-resistant polyurethane.
- To use a Series Versi II pig for different applications, cups can simply be added or reconfigured.

Designed to negotiate 1.5D bends, the Versi II pig moves reliably through piping systems.

Options Available:

- Variety of configurations and durometers.
- Circular flange brushes in the following types and trim materials:
 1. Trim types – flat wire or pencil.
 2. Trim material – carbon steel, stainless steel or plastic.

ALL URETHANE

VERSI III - modular cast

6-20" (152-508mm)

Versatility is the name of the game for the durable, lightweight Series Versi III. Because it can do so many jobs, this all-urethane pipeline pig is extremely economical. By fitting it with a combination of a sealer and cup, it is very effective and versatile for cleaning, batching, and displacement operations.

The solid urethane shaft of the Versi III is very flexible. This means that over time, sealing elements wear evenly, addressing an inherent problem with heavy steel mandrel shafts.

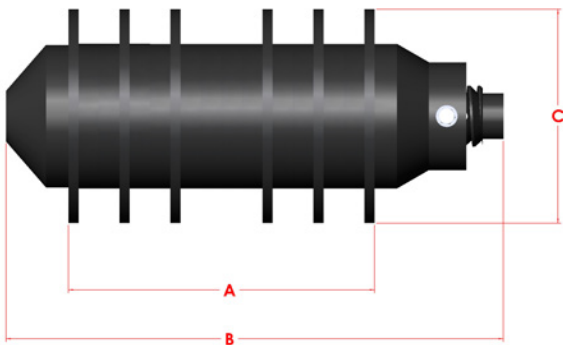

Size	A	B	C	Part #
6"	9.250	15.375	6.375	73-0553-06
8"	12.000	19.875	8.375	73-0553-08
10"	15.000	24.375	10.500	73-0553-10
12"	17.500	27.625	12.500	73-0553-12
14"	21.250	30.750	13.875	73-0553-14
16"	24.000	36.125	15.875	73-0553-16
20"	29.750	43.125	20.000	73-0553-20

Features & Benefits:

- There are no metal parts to bend, corrode or damage pipe lining.
- Rather than replacing the entire assembly when individual parts become worn, they are easily removed and replaced, saving time and money.
- Every Series Versi III pig is equipped with Apache cups and discs. As with all of Apache products, they were specifically developed to perform, efficiently and reliably. To maximize durability, they're made from Reliathane, Apache's special blend of wear-resistant polyurethane.
- To use a Series Versi III pig for different applications, cups can simply be added or reconfigured.

Designed to negotiate 1.5D bends, the Versi III pig moves reliably through piping systems.

Options Available:

- Variety of configurations and durometers.
- Circular flange brushes in the following types and trim materials:
 1. Trim types – flat wire or pencil.
 2. Trim material – carbon steel, stainless steel or plastic.

ALL URETHANE

VIPRS® & SUD® PIG

2-10" (51-254mm)

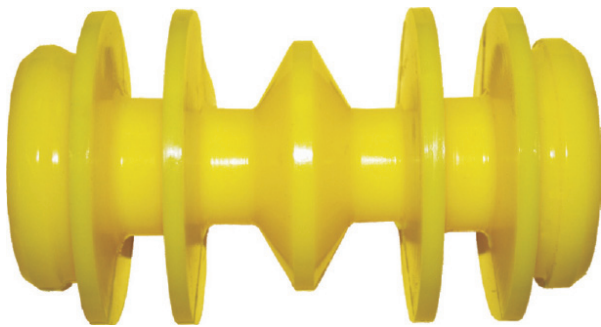

VIPRS® PIG

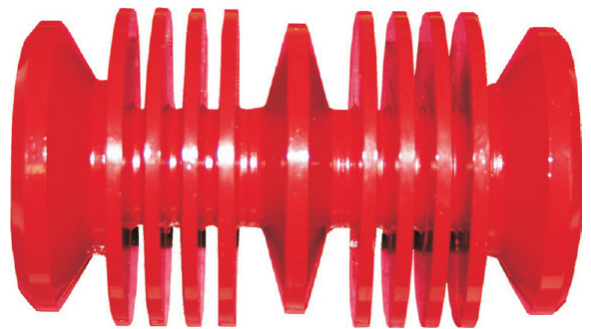

SUD® PIG

Applications:

- Terminal loading lines.
- Chemical processing.
- Petrochemical.
- Wood pulp and paper.
- Food and beverage.
- Water and wastewater treatment plants.
- Packaging, loading, process and product lines and piping.

Technical Benefits:

- Less wasted product means reduced BOD load charges.
- Reduced power costs mean greater efficiencies of flow and pressure.
- Cleaner product as a result of decreased product intermix.
- Reduced overtime through more efficient, faster clean-up.

Options Available:

- Trip Magnets for non-intrusive pig indicators.
- Available in polyurethane compounds for pipe and tubing sizes through 12". Nitrile, Viton® and other compounds available on request.
- Food grade material available.

Features:

- Provides a smooth, tight squeegee action while traversing elbows with radius as sharp as 1.5D.
- Batching and liquid removal at pressures as low as 15 PSI.
- Accommodates variations in pipe IDs of the same nominal size.

Designed to traverse 1.5D bends.

 *Apache Pipeline Products acknowledges the design contribution from Inline Services.

1575 - 90 Ave Edmonton, AB Canada T6P 0E2

Ph: 780.416.4850 | Fax: 780.416.4829 | apachepipe.com | Email: sales@apachepipe.com

4-17

world class world wide

ALL URETHANE

VIPRS® & SUD® PIG

2-10" (51-254mm)

VIPRS® PIG

Size	Pipe I.D.	Description	Seal Discs O.D.	Overall Length
2"	1.870"	For SS Tubing	1.900"	3.400"
2"	2.067"	For S/40	2.100"	3.400"
2"	2.157"	For S/10	2.200"	3.400"
2.5"	2.370"	For SS Tubing	2.400"	4.600"
2.5"	2.637"	For S/10	2.700"	4.600"
3"	2.870"	For SS Tubing	2.900"	5.500"
3"	3.068"	For S/40	3.100"	5.500"
3"	3.260"	For S/10	3.300"	5.500"
3"	n/a	For S/5	3.400"	5.500"
4"	3.834"	For SS Tubing	3.900"	6.380"
4"	4.026"	For S/40	4.100"	7.500"
4"	4.260"	For S/10	4.320"	7.500"
6"	5.782"	For SS Tubing	5.900"	9.500"
6"	6.357"	For S/10	6.450"	9.500"
10"	n/a	For S/40	10.340"	17.360"

SUD® PIG

Size	Pipe I.D.	Description	Seal Discs O.D.	Overall Length
2"	1.870"	For SS Tubing	1.900"	3.800"
2"	2.067"	For S/40	2.100"	3.800"
2"	2.157"	For S/10	2.200"	3.800"
2.5"	2.370"	For SS Tubing	2.400"	4.600"
2.5"	2.469"	For S/40	2.500"	4.600"
2.5"	2.637"	For S/10	2.700"	4.600"
3"	2.870"	For SS Tubing	2.900"	5.500"
3"	3.068"	For S/40	3.150"	5.500"
3"	3.260"	For S/10	3.300"	5.500"
3"	n/a	For S/5	3.400"	5.500"
4"	3.834"	For SS Tubing	3.900"	7.750"
4"	4.026"	For S/40	4.150"	7.750"
4"	4.260"	For S/10	4.300"	7.750"
4"	4.334"	For S/5	4.460"	7.750"
6"	5.782"	For Tubing	5.900"	10.760"
6"	6.065"	For S/40	6.200"	10.760"
6"	6.357"	For S/10	6.400"	10.760"
8"	7.981"	For S/40	8.150"	15.420"
8"	8.329"	For S/10	8.450"	15.420"
8"	n/a	For S/5	8.625"	n/a
10"	n/a	For S/5 or S/10	10.220"	17.180"
12"	n/a	For S/40	12.250"	16.930"