

INSTALLATION - REASSEMBLY

Install Height Adjustment

1. Reinstall DUST SEAL to LOWER HOUSING **(Figure 7)**
2. Using two (2) screws provided, install UPPER HOUSING ASSEMBLY to the LOWER HOUSING **(Figure 7)**
3. With the FLAG in the "UP" position, reinstall FLAG PUSH ROD and seat RESET ROD back in place **(Figure 7)**
4. Set LOAD SPRING onto RESET ROD **(Figure 7)**
5. Install LID using two (2) screws provided **(Figure 7)**
6. Screw RESET BUTTON onto RESET ROD ensuring it turns freely **(Figure 7)**
7. Push down on RESET BUTTON to fully extend PLUNGER into pipe bore. Put FLAG into "DOWN" position **(Figure 7)**
8. Adjust MAIN ASSEMBLY by turning UPPER HOUSING clockwise or counter clockwise to attain INSTALL HEIGHT **(Figure 8)** marked on TAG located on UPPER HOUSING ASSEMBLY. LOCK SCREW may need to be loosened.

Note: See illustration for detailed drawing.

9. Tighten LOCK SCREW to secure MAIN ASSEMBLY and slide DUST SEAL onto 2" NPT ADAPTER **(Figure 9)**



IMPORTANT Detection of pig's passage is dependent on proper Install Height. Incorrect Install Height could void the warranty

pigPRO™

INSTALLATION INSTRUCTIONS

Series 57 Visual Indicator
with Manual Reset



PRIOR TO INSTALLATION

Be sure to read the information in this manual carefully before you install the Apache pigPRO indicator

Use these precautions when installing and adjusting the Apache pigPRO indicator:

- ➔ Do not damage top threads of 2" NPT ADAPTER.
- ➔ Thread 316SS 2" NPT ADAPTER hand tight into thread-O-let before tightly securing with pipe wrench.
- ➔ Do not strike the RESET BUTTON.
- ➔ Do not tighten LOWER HOUSING to seal. LOWER HOUSING unit should be turned only for PLUNGER adjustment.

Prior to installing your Series 57 pigPRO Visual Indicator:

- ➔ Cut/drill 1-1/4" coupon from the pipeline. ⚠
- ➔ Center 2" 3000lb. thread-O-let over the opening and weld to applicable codes.



Do not install or remove in a pressurized pipeline without first acquiring the services of a qualified hot tap specialist.

All Apache Pig Passage Indicators are shipped from the factory assembled and tested.

APACHE pigPRO SERIES 57 Visual Indicator with Manual Reset

NON-PRESSURIZED LINE APPLICATION

No disassembly or internal adjustment required when mounting onto a non-pressurized line.

1. Apply thread sealant to bottom threads of 2" NPT ADAPTER and tighten clockwise the MAIN ASSEMBLY with 2" NPT ADAPTER into 2" 3000 lb thread-O-let (**Figure 1**). Use pipe wrench to securely tighten 2" NPT ADAPTER ensuring no damage to the threads occur.

2. Loosen LOCK SCREW on 2" NPT ADAPTER (**Figure 2**).

Note: There is no need to separate 2" NPT ADAPTER from the MAIN ASSEMBLY.

3. Adjust MAIN ASSEMBLY by turning UPPER HOUSING ASSEMBLY clockwise or counter clockwise to attain INSTALL HEIGHT (**Figure 3**) marked on TAG located on UPPER HOUSING ASSEMBLY.

Note: See back page for detailed drawing.

4. Tighten LOCK SCREW to secure MAIN ASSEMBLY and slide DUST SEAL onto 2" NPT ADAPTER (**Figure 4**).

APACHE pigPRO KEY COMPONENTS



PRESSURIZED LINE APPLICATION

On-stream installation requires portions of the pigPRO to be disassembled

PRIOR TO INSTALLATION - DISASSEMBLE

1. Remove RESET BUTTON by simultaneously applying upward pressure and turning counter clockwise (**Figure 5**).

2. Remove two (2) screws allowing removal of LID (**Figure 5**).

Note: DO NOT remove JAM NUT or LOAD SPRING ADJUSTER from LID.

3. Remove LOAD SPRING from RESET ROD (**Figure 5**).

4. With FLAG in the "UP" position remove RESET ROD and FLAG PUSH ROD (**Figure 5**).

5. Remove two (2) screws and lift UPPER HOUSING ASSEMBLY and DUST SEAL from LOWER HOUSING (**Figure 6**).

6. Loosen LOCK SCREW and remove LOWER HOUSING from 2" NPT ADAPTER by turning counter clockwise ensuring it is not exposed to dirt or other contaminants. (**Figure 6**).

7. Apply thread sealant tape to the outside top and bottom threads of 2" NPT ADAPTER and tighten into existing thread-O-let.

Caution: Do not apply sealant tape to internal threads

HOT TAP PROCEDURE

1. Utilizing a trained hot tap technician, connect hot tap apparatus to 2" NPT ADAPTER and follow standard hot tapping procedures to drill and remove 1-1/4" coupon.

Caution: Careful not to scratch ID sealing surface upon removal of coupon.

2. Ensuring hot tap machine is depressurized above ball valve, disconnect and attach Apache HOT TAP ADAPTER to LOWER HOUSING fastening with the two (2) screws provided.

Note: The HOT TAP ADAPTER fits most industry hot tap machines.

3. Connect the LOWER HOUSING & HOT TAP ADAPTER to hot tap machine.

APACHE pigPRO KEY COMPONENTS

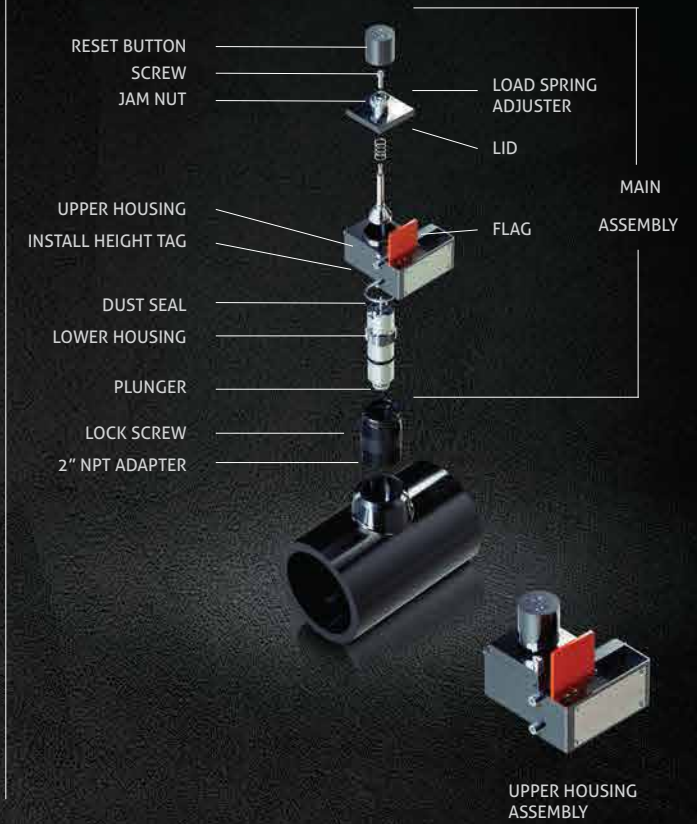

FIGURE 1



FIGURE 2



FIGURE 3



FIGURE 4



FIGURE 5

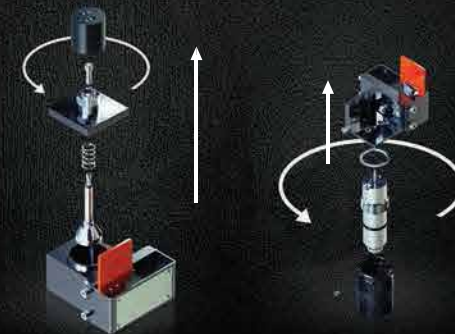

FIGURE 6



FIGURE 7



FIGURE 8



FIGURE 9



APACHE HOT TAP ADAPTER
Not included