

## INSTALLATION - REASSEMBLY (Figure 8-9)

### Install Height Adjustment

1. IMPORTANT to tighten LOCK SCREW to prevent removal of LOWER HOUSING prior to loosening screws to remove HOT TAP ADAPTER.
  2. Reinstall DUST SEAL to LOWER HOUSING.
  3. Place rubber GASKET on top of the LOWER HOUSING.
  4. Using screws provided, install LOWER END CAP to the LOWER HOUSING (Figure 7).
  5. Maintaining PLUNGER ROD EXTENSION within the EXTENSION POLE, carefully place the drilled end of the PLUNGER ROD EXTENSION onto the PLUNGER (Figure 8).
  6. Lower EXTENSION POLE onto LOWER END CAP and gently turn ensuring no cross threading occurs.
- Caution:** PLUNGER ROD EXTENSION must remain on the PLUNGER ROD.
7. Reinstall UPPER HOUSING to top of EXTENSION POLE (Figure 9).
  8. With the FLAG in the "UP" position, reinstall FLAG PUSH ROD and seat RESET ROD back in place.
  9. Set LOAD SPRING onto RESET ROD.
  10. Install LID using screws provided.
  11. Screw RESET BUTTON onto RESET ROD ensuring it turns freely.
  12. Push down on RESET BUTTON to fully extend PLUNGER into pipe bore. Put FLAG into "DOWN" position.
  13. Adjust to INSTALL HEIGHT (see tag on unit or on documentation)/ LOCK SCREW may need to be loosened. Upon completion tighten LOCK SCREW.



**IMPORTANT:** Detection of pig's passage is dependent on proper INSTALL HEIGHT. Incorrect INSTALL HEIGHT could void the warranty.

## pigPRO™

### INSTALLATION INSTRUCTIONS

Series 57 Visual Indicator with  
Manual Reset Extension Pole





## PRIOR TO INSTALLATION

Be sure to read the information in this manual carefully before you install the Apache pigPRO indicator

### Use these precautions when installing and adjusting the Apache pigPRO indicator:

- ➔ Do not damage top threads of 2" NPT ADAPTER.
- ➔ Thread 316SS 2" NPT ADAPTER hand tight into thread-O-let before tightly securing with pipe wrench.
- ➔ Do not strike the RESET BUTTON.
- ➔ Do not tighten LOWER HOUSING to seal. LOWER HOUSING unit should be turned only for PLUNGER adjustment.

### Prior to installing your Series 57 pigPRO Visual Indicator:

- ➔ Cut/drill 1-1/4" coupon from the pipeline.
- ➔ Center 2" 3000lb. thread-O-let over the opening and weld to applicable codes.

⚠ Do not install or remove in a pressurized pipeline without first acquiring the services of a qualified hot tap specialist.

All Apache Pig Passage Indicators are shipped from the factory assembled and tested.

### APACHE pigPRO SERIES 57 Visual Indicator with Manual Reset

## NON-PRESSURIZED LINE APPLICATION

No disassembly or internal adjustment required when mounting onto a non-pressurized line.

1. Apply thread sealant to bottom threads of 2" NPT ADAPTER and tighten clockwise the MAIN ASSEMBLY with 2" NPT ADAPTER into 2" 3000 lb thread-O-let (**Figure 1**). Use pipe wrench to securely tighten 2" NPT ADAPTER ensuring no damage to the threads occur.
2. Loosen LOCK SCREW on 2" NPT ADAPTER (**Figure 2**). Note: There is no need to separate 2" NPT ADAPTER from the MAIN ASSEMBLY.
3. Adjust MAIN ASSEMBLY by turning UPPER HOUSING ASSEMBLY clockwise or counter clockwise to attain INSTALL HEIGHT (**Figure 3**) marked on TAG located on UPPER HOUSING ASSEMBLY.
4. Tighten LOCK SCREW to secure MAIN ASSEMBLY and slide DUST SEAL onto 2" NPT ADAPTER (**Figure 4**). Note: See back page for detailed drawing

### APACHE SERIES 57 Standard pigPRO KEY COMPONENTS

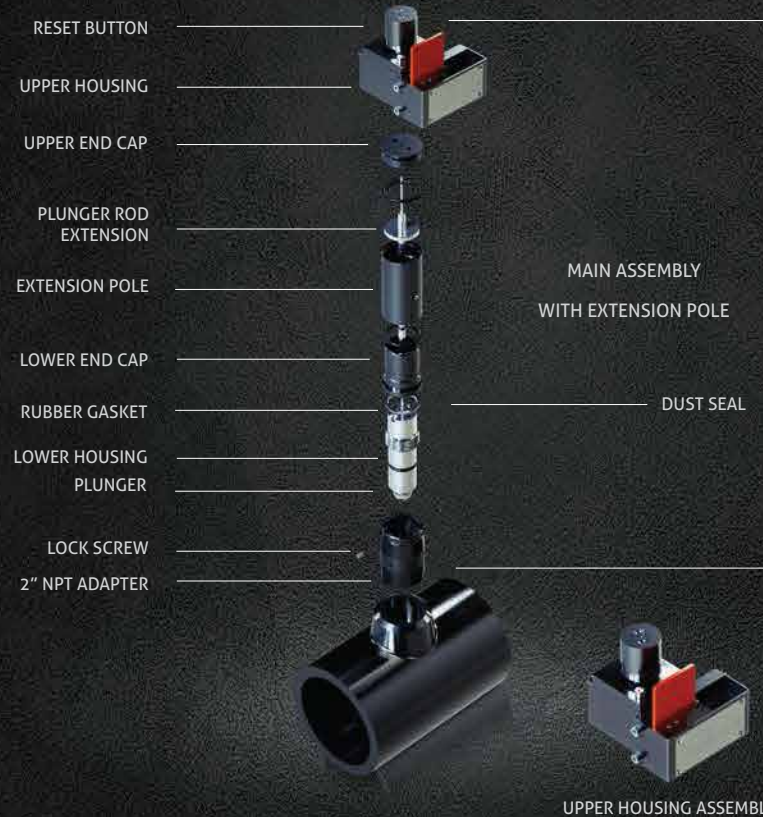

## PRESSURIZED LINE APPLICATION

On-stream installation requires portions of the pigPRO to be disassembled

### PRIOR TO INSTALLATION - DISASSEMBLE (FIGURES 5-7)

1. Remove RESET BUTTON by simultaneously applying upward pressure and turning counter clockwise (**Figure 5**).
2. Remove two (2) screws allowing removal of LID (**Figure 5**).  
*Note: DO NOT remove JAM NUT or LOAD SPRING ADJUSTER from LID.*
3. Remove LOAD SPRING from RESET ROD.
4. With FLAG in the "UP" position remove RESET ROD and FLAG PUSH ROD.
5. Keep LOWER END CAP stationary (use wrench if necessary), and turn EXTENSION POLE until loose (**Figure 6**). Prior to removal ensure both the EXTENSION POLE and PLUNGER ROD EXTENSION (loose within EXT. POLE) are lifted simultaneously.  
**Caution:** Lift vertically when separating. Damage to PLUNGER ROD can occur if removed incorrectly.
6. Turn UPPER HOUSING ASSEMBLY to remove from EXTENSION POLE. UPPER END CAP remains connected to UPPER HOUSING ASSEMBLY.
7. Remove two (2) screws and lift LOWER END CAP from LOWER HOUSING (**Figure 7**).
8. Loosen LOCK SCREW and remove LOWER HOUSING from 2" NPT ADAPTER by turning counter clockwise ensuring it is not exposed to dirt or other contaminants. Remove black DUST SEAL (**Figure 7**).

9. Apply thread sealant tape to the outside top and bottom threads of 2" NPT ADAPTER and tighten into existing thread-O-let.

**Caution:** Do not apply sealant tape to internal threads

### HOT TAP PROCEDURE

1. Utilizing a trained hot tap technician, connect hot tap apparatus to 2" NPT ADAPTER and follow standard hot tapping procedures to drill and remove 1-1/4" coupon.
2. Ensuring hot tap machine is depressurized above ball valve, disconnect and attach Apache HOT TAP ADAPTER to LOWER HOUSING fastening with the two (2) screws provided.

**Note:** The HOT TAP ADAPTER fits most industry hot tap machines.

### APACHE pigPRO KEY COMPONENTS

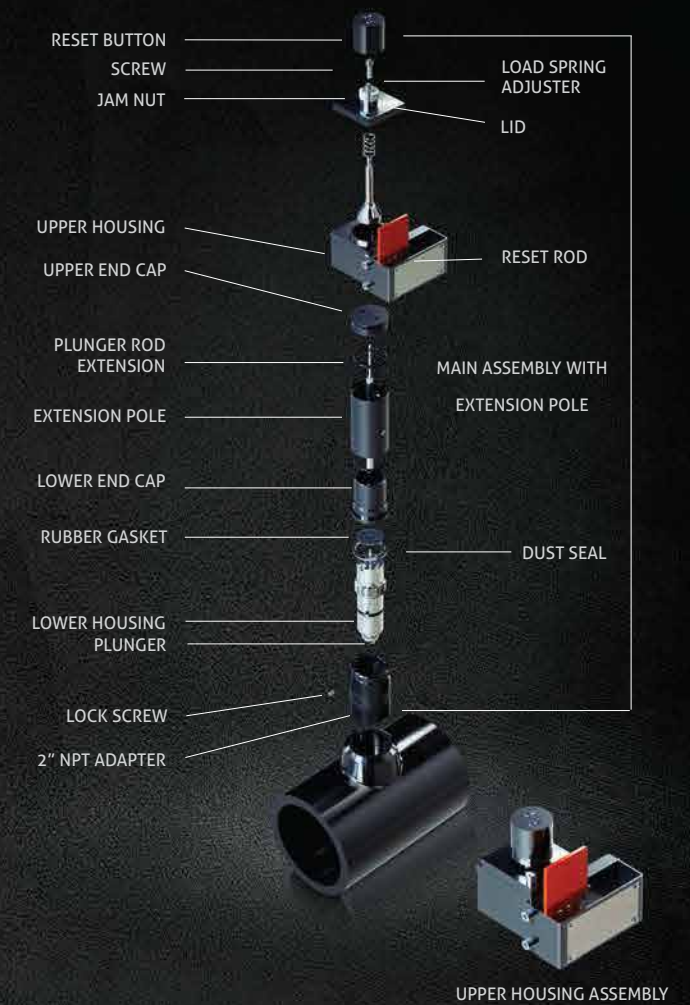

3. Connect the LOWER HOUSING & HOT TAP ADAPTER to hot tap machine.

4. **GENTLY** engage the stainless steel thread of the LOWER HOUSING to the 2" NPT ADAPTER. Do not gall threads. Ensure the LOWER HOUSING is securely threaded & sealed to 2" NPT ADAPTER prior to removal of hot tap equipment



FIGURE 1



FIGURE 2



FIGURE 3



FIGURE 4



FIGURE 5

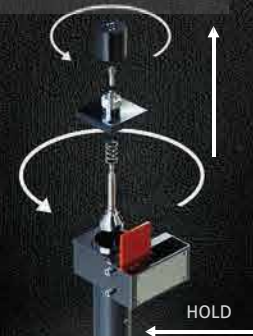

FIGURE 6



FIGURE 7



FIGURE 8



FIGURE 9

